

BACKFIRE F5F

Petr Janku
Hermanice 72
Nova Paka
50901

Mail: ing.petr.janku@gmail.com
f5b@f5b.cz
Web: <http://www.f5b.cz>
Phone: +420 728 304 793



Thank You for buying the model of Backfire F5F. Backfire F5F is a full-carbonic model, it is made by lamination into negative forms. Backfire F5F is suitable for the competitive league F5F¹, F5B/7, and for the hobby flying as well. The model was designed for competitive flying and its design results from the latest innovation of the F5F category. The aerodynamic was created by the German expert Dirk Pflug.

The fuselage is full-carbonic and there is a possibility to make an Aramid or a glass fuselage as well, if the customer requests that. The wing is also full-carbonic and there is a carbon cloth 93g/m² with an orientation of $\pm 45^\circ$ on its surface, which inhibits from wing-twisting. The spar is made of UMS roving. The standard wing is made of one part, but there is a possibility to produce the three-part² wing according to customer's wish. The elevator is made of glass with a carbon flap of the cloth 93g/m².

There is also a possibility to produce a model – version „Show“ for an extreme flying. Be very cautious while flying with „Show“, because it allows to reach high flying-speeds you should avoid the situation when you could damage someone's assets or hurt someone.

1 Model

1.1 The Kit's content

Fuselage	1	pc
Wing	1	pc
V-tail	1	pc
Connector MPX	2	pc
Barrier motor	1	pc
Wing horn	4	pc
Screw for wing	2	pc
Barrier into fuselage for servos	1	pc
Wires for servo	4	pc
Brass wires 2mm	4	pc
Ball pivots – servo	2	pc
Ball pivots – V-tail	2	pc
Threaded rod 2mm	4	pc
Carbonic rod 700mm	2	pc

¹ It is necessary to use solid (one part) wing.

² The three-part wing is designed for the hobby (recreational)-flying. It is necessary to take into account, that this wing does not reach the strenght of the one-part wing.

Crapping strips	4	pc
-----------------	---	----

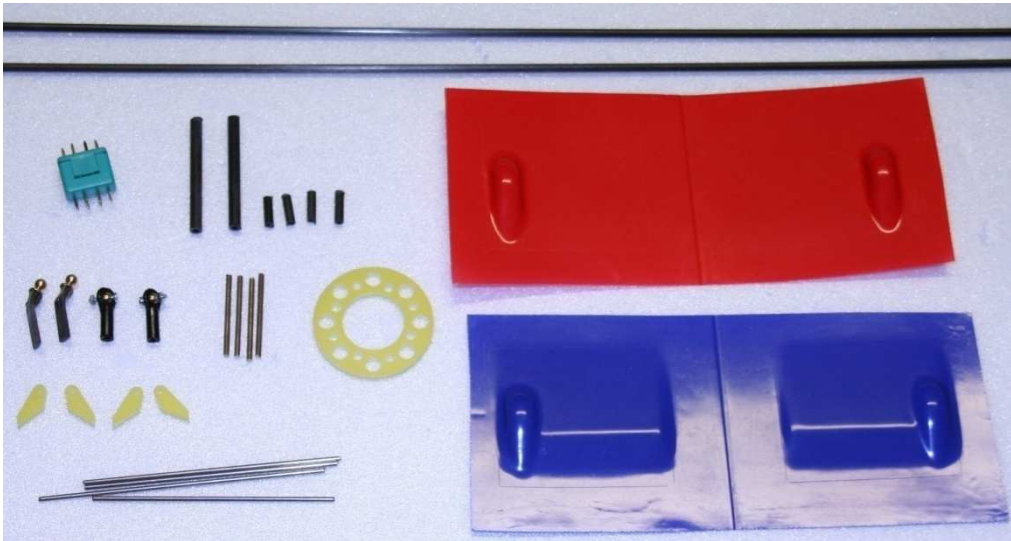

Picture 1: Accessories

1.2 The fittings needed for completing

- The cone – diameter 38mm
- Second glue – medium
- Activator for the second glue
- The epoxide R+G L-285
- The consolidator R+G 285
- Micro-ballons + Aerosil
- Utility knife
- Transparent cellotape which does not leave a glue behind
- Soldering unit
- Turn-bench Dremel
- Servoconnectors

1.3 Recommended components

1.3.1 Motors

It is possible to use any engine with the power from 200W to 2500W. The optimal engine weight for competitive flying is c. 280g.

Hacker	B50 F5B	B40 F5F
Kontronik	Fun 500	Kira 600
Neu Motors	1509 F5F	1512
Plettenberg	<u>HP 220/30/A1 P6 5:1</u> <u>HP 220/30/A1 P6 7:1</u>	<u>HP 220/25/A1 P6 7:1</u> <u>HP 220/25/A1 P6 5:1</u>

1.3.2 Propeller

3S1P 17x18 with 7:1 gear

4S1P 16x16 with 7:1 gear

1.3.3 Batteries

3s	Kokam 4000 EHD	4000	mAh	30C	147x43x29mm
3s	Wide Energy WE 5000 SHD	5000	mAh	30C	157x43x27mm
3s	Wide Energy WE 4100 SHD	4100	mAh	30C	157x43x30mm
3s	Hi model 4600	4600	mAh	25C	165x48x24mm ³
3s	TopFuel Hacker	5000	mAh	30C	155x43x29mm
4s ⁴	Desire Power	4500	mAh	33C	165x44x35mm ⁵
4s	Neu4100EP	4100	mAh	30C	160x45x31mm
4s	Neu4900Xp	4900	mAh	25C	165x44x34mm
4s	Hi model 3200	3200	mAh	25C	139x45x28mm
5s	Hi model 3200	3200	mAh	25C	139x45x36mm ⁶
5s	FlightPower Hacker	3200	mAh	20C	144x45x32mm

1.3.4 Servos

Ailerons	Hitec HS-125	Hitec HS-5125 MG	Volz Wing Max
Flasp	Hitec HS-125	Futaba S-3150	Volz Wing Max
V-tail	Futaba S-3114	Futaba S-3154	

³ With 4/5s it is necessary to count with connecting the conductors directly at regulator (the conductors cannot be drawn on the battery)

⁴ Practically it is possible to use any kind of battery with the maximum size of 170x45x35 mm

⁵ As long as the battery-high isn't over 27mm, it is possible to use a battery up to 48 mm wide

⁶ This battery slightly pushes on the wing, if there is no need to use 5s battery, it is better to avoid it

1.3.5 Receiver batteries

Intellect	AAA-750 mAh	A-1400 mAh
X Cell	AAA-1000mAh	
GP	A-1100 mAh	A-1300mAh

2 Fuselage

2.1 Cooling hole

First we mark the place of the cooling air's entrance with the felt tip and we cut through the carbonic fuselage by using a knife. We press down the cut cooling entrance under the fuselage level and we fix it with help of balsa – 2mm of thickness. We apply an epoxid with microballons on the side rim of the cooling entrance and we leave the fuselage to hardend.



Picture 2: The cooling air's entrance

It is possible to make the cooling air's entrance in the wing with help of a carbonic tubule with the 14 mm diameter. The place for leaks is marked on the wing.

2.2 V-tail shoulder

The carbonic pins must be ground at their ends with help of a turn-bench and so their edges are flicked off. Those pins that will be stuck up in the fuselage must be roughened, so the pins will hold to fuselage well. We glue everything with the epoxide. Next we cut through the holes for the butterfly-lever. The hole is marked directly on the fuselage. We glue the enclosed levers into the butterfly. The lever should be slipped into butterfly as much as possible. We check the levers-position in fuselage after the glueing.

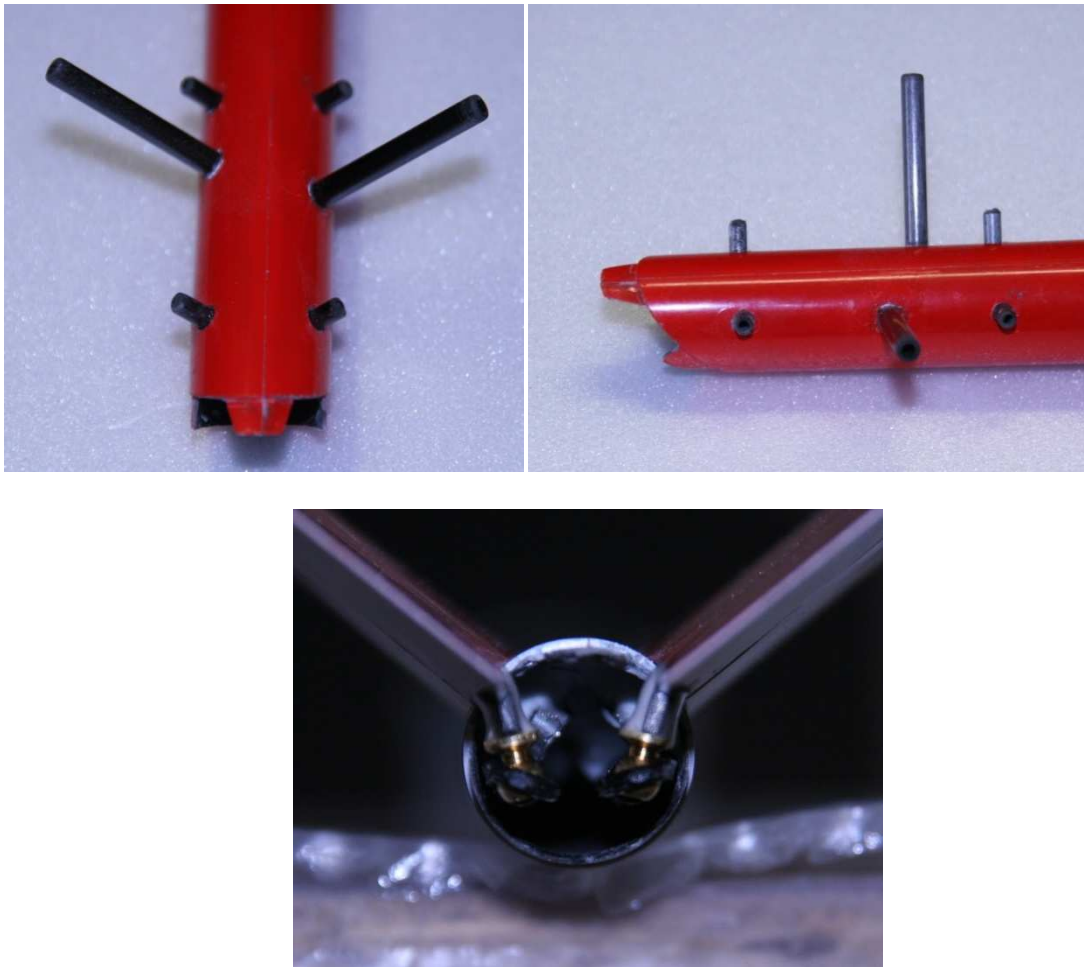

Picture 3: The soulder for V-tail

2.3 How to glue the butterfly's servos

We shorten the carbonic pull at the length 645mm and 630mm. We grind their ends again and flick off the edges. We flick off the edges of threaded rods M2 too. We glue the threaded rods M2 into both sides of carbonic pulls in the way so that approximately 10mm of the carbonic pulls sticks out the carbonic pipe. We screw the boll cups at one side.

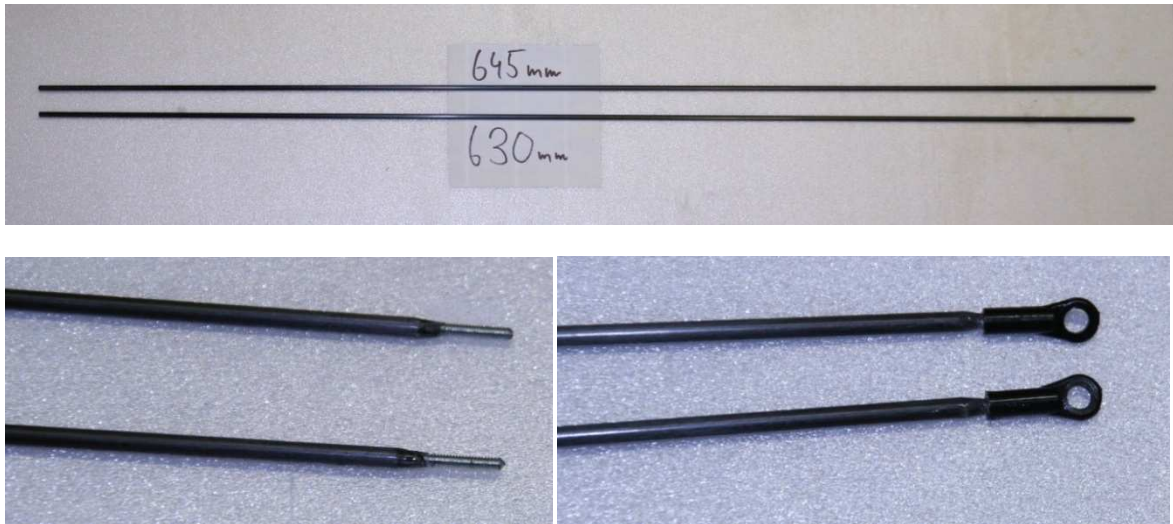

Obr. 4: The carbonics pulls for V-tail

We screw the servos into prepared barrier and we glue their bolts with the fusing gun so that we could unloose the bolts in case we suffuse them by the epoxide. We secure the servos cables in the same way.

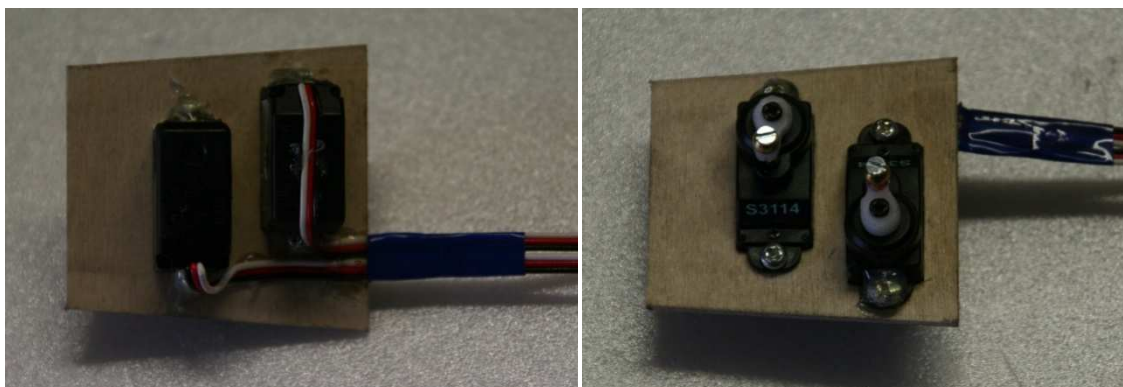

Picture 5: The barrier for the butterfly's servos

We give the barrier into the fuselage and set the servos' neutrals. At the end of fuselage we screw the next boll cups. It is absolutely necessary that the pulls are put through the guide tubule in the middle of the fuselage!!!

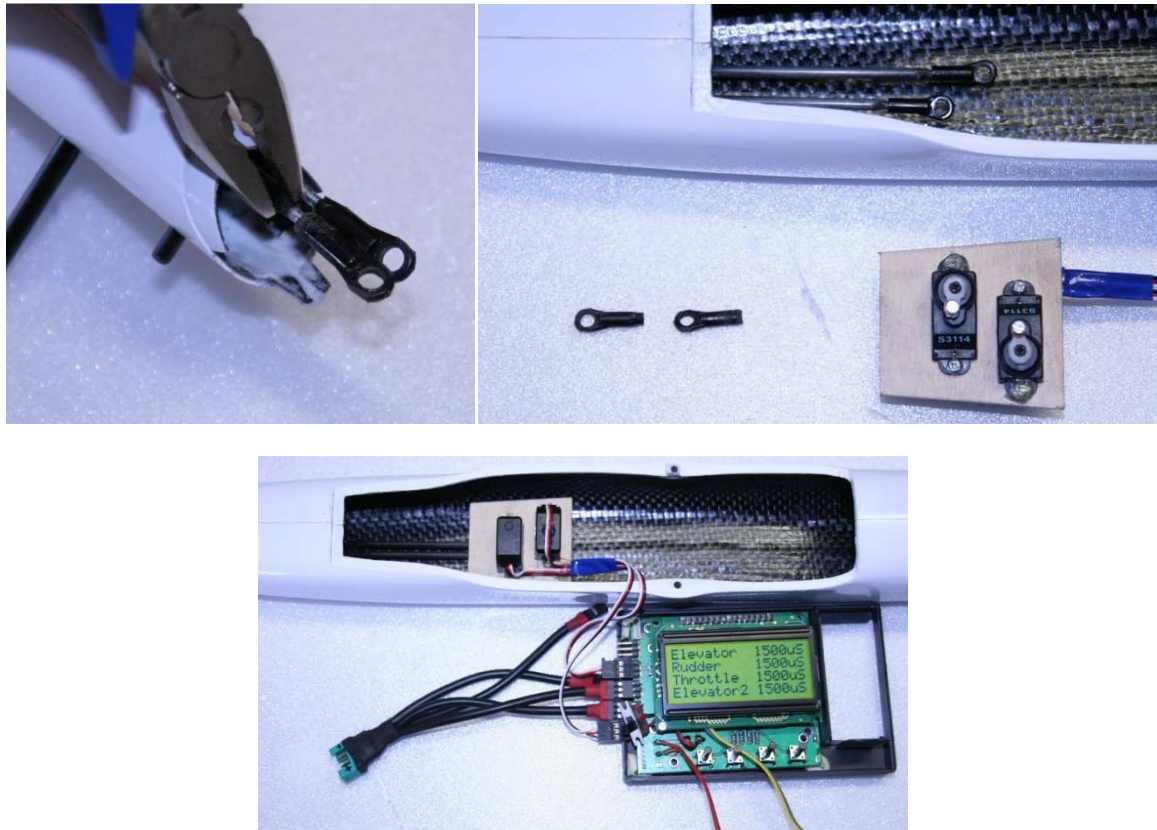

Picture 6: Putting in the servos and setting up the neutrals

We apply the epoxide with microballons thickened by aerosil on the barrier in the way that the mixture do not slump. We inset the barrier into the fuselage inchmeal and turn the fuselage upside-down. On the other side we set the ball pivot of butterfly in the cup on the carbonic pull. The butterfly-flap must be secured against the movement with help of cellotape.

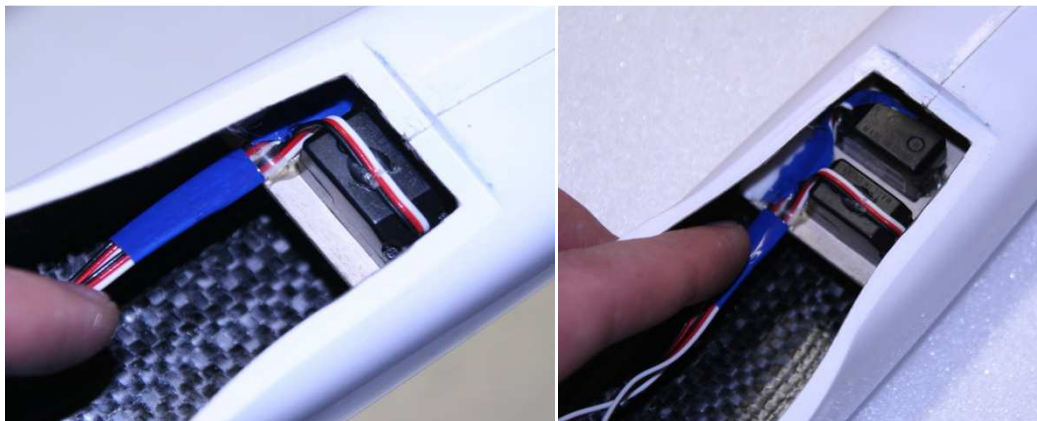

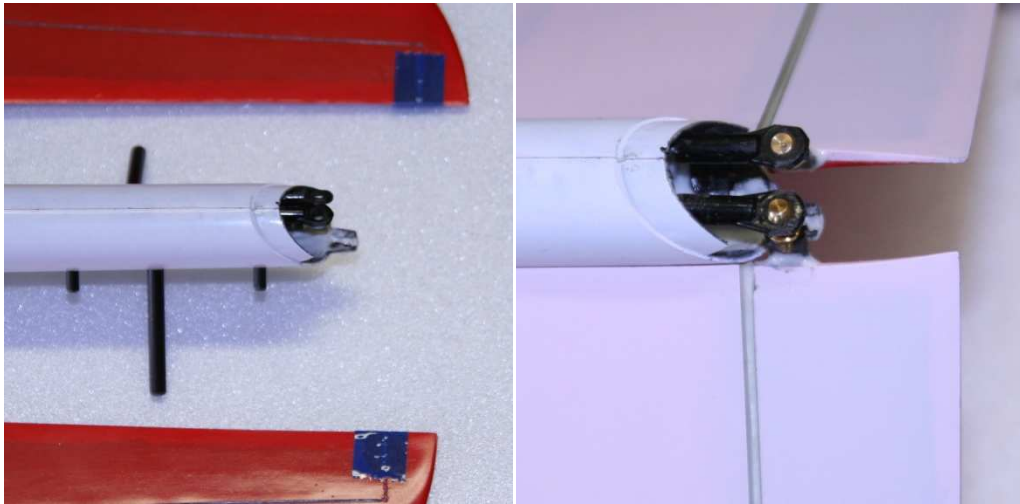

Picture 7: Glueing V-tail servos

Next we can put two balsa-battens⁷ with 1mm thickness between ball pivots on the servo and the fuselage-bottom. The battens ensure the space needed for ball pivots movement. We check the quality of glued joint. It is necessary to fix the butterfly to the fuselage before the test flying. The best way is to stick the butterfly with epoxide glue.

⁷ if it is obvious that the gap is bigger than 2mm it is not necessary to put in those balsa-battens

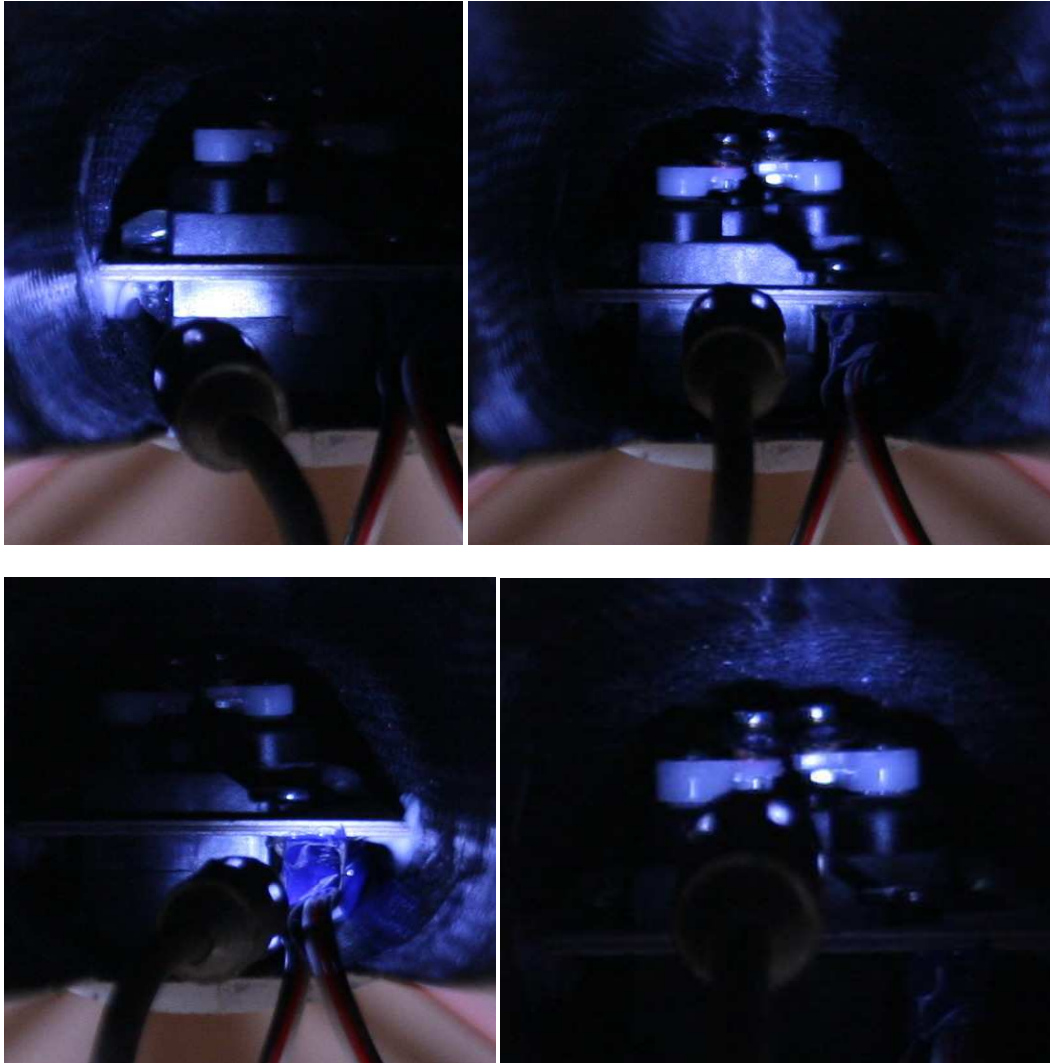

Picture 8: Control of the glued barrier

2.4 Motor Barrier

On circuit we make kerfs by using the saw or the milling machine. We screw the barrier to the engine and protect the engine by using the cello tape against the possible epoxide-pollution with. We apply the epoxide with ballons thickened by aerosil behind the edge of the shoulder in the fuselage. We put the engine in the fuselage, we set the cone. We fix the cone to the fuselage with help of cello tape. We let to harden the fuselage in the vertical position.



Picture 9: The glued-in of the engine-barrier

3 Wing

3.1 Horns and Pulls

We glue the levers⁸ belonging in the flap in the distance of 7,3mm from the axis of rotation and the levers for wings in the distance of 4,4mm from the axis of rotation. The lever of the flap's servo will have the hole in the distance of 7,3mm⁹ from the axis of rotation and the lever of the butterfly's servo in the distance of 3,0mm¹⁰. The pull for the flap is 38mm long and for the wing 29mm. The pull is made of steel wire with the diameter 1,5mm and of brass lumber with the diameter 2mm. We cut c. 2mm of thread in the brass lumber and we bend the lumber in the shape of the letter L and we finish the thread. The thread should be c. 5mm long. We bend the steel wire only and the length of the bend should be c. 5mm too. We roughen the places which we are going to solder by using an emery paper. In the lever of the flap's servo we cut the M2-thread and we glue up the female screws. It is necessary to grid down the servo shaft by the lever of flap.

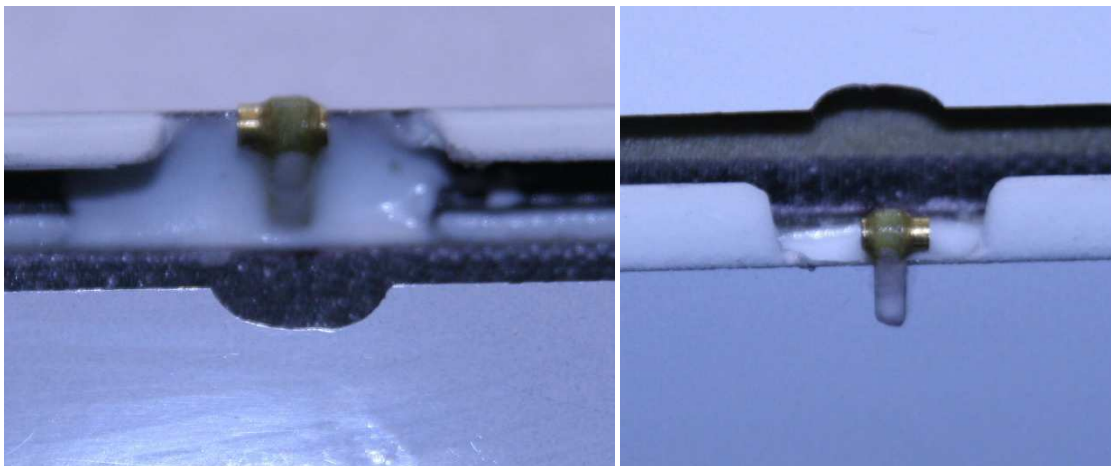

⁸ I recommend to complement the levers with the brass case with the diameter 2,5/1,52mm and the length 4mm

⁹ when the lever of the servo and the flap have the same distance, then by the servo-deflection of 90° the flap-deflection is 90° too

¹⁰ when we use this proportion, the wing-deflection is c. 8mm by up motion and c. 6mm by down motion

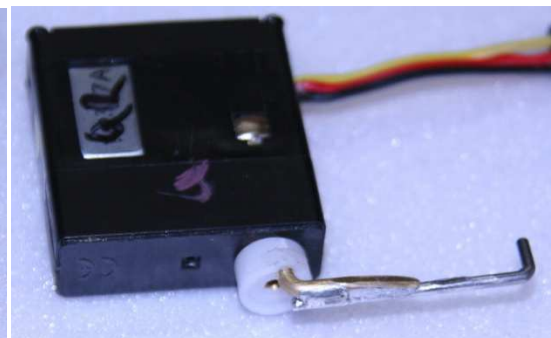
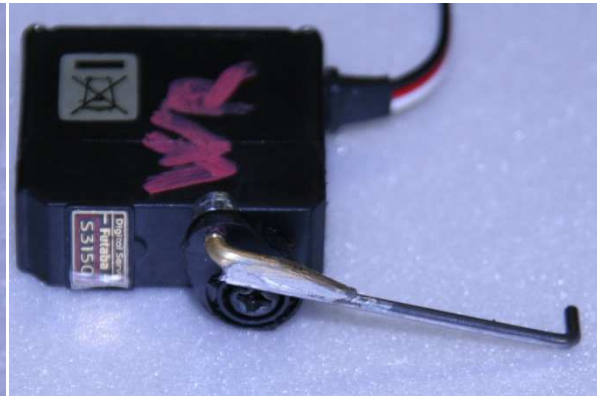
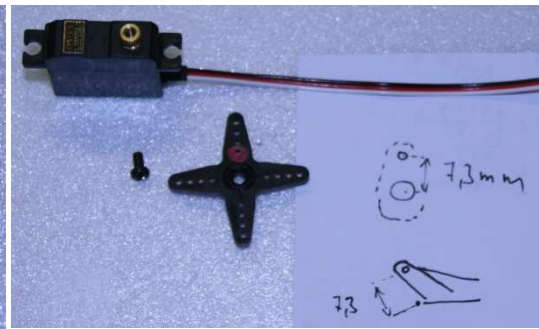
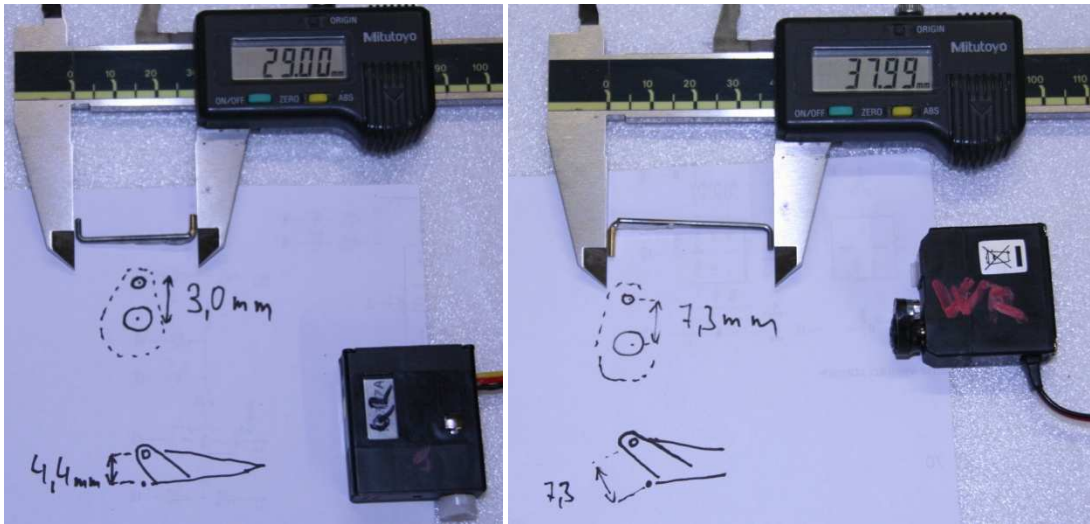

Picture 10: Levers and pulls of the wing

3.2 Cabels of servos and servoholder

We shorten the servos' cables up to 4cm of distance. We solder the pins from the crushing bar on the servos' cables pulled through the wing. Or we can crimpen the original pins from the servo-connector. We prepare the septa from plywood 1,5mm for each servo.

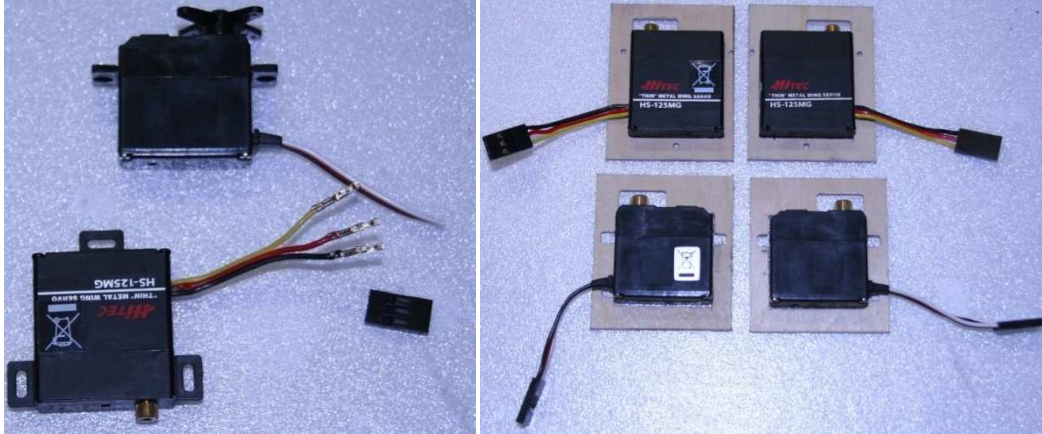

Picture 11: The cables of servos and septa of servos

3.3 Connectors Wing/Fuselage

In case we work with the three-piece wing, we have to solder the connectors into wings first and then we glue up them with an epoxide glue. After this the next work procedure is the same like working with the one-piece wing.



Picture 12: The connector for aileron of three-piece wing

The length of cables to the receiver should be c. 9cm. We strip cables, tin-plate them and we put the shrink- spaghetti insulation on them. We solder cables to the connector MPX, strip the isolation with the hot-air gun and fix all with the fusing gun. We use the same work procedure while soldering the connector MPX in the wing. We let the cables so long that their distance from the end of the wing is c. 3cm. And, beside the shrink- spaghetti insulation, we pull on the silicone insulation on the cable too.

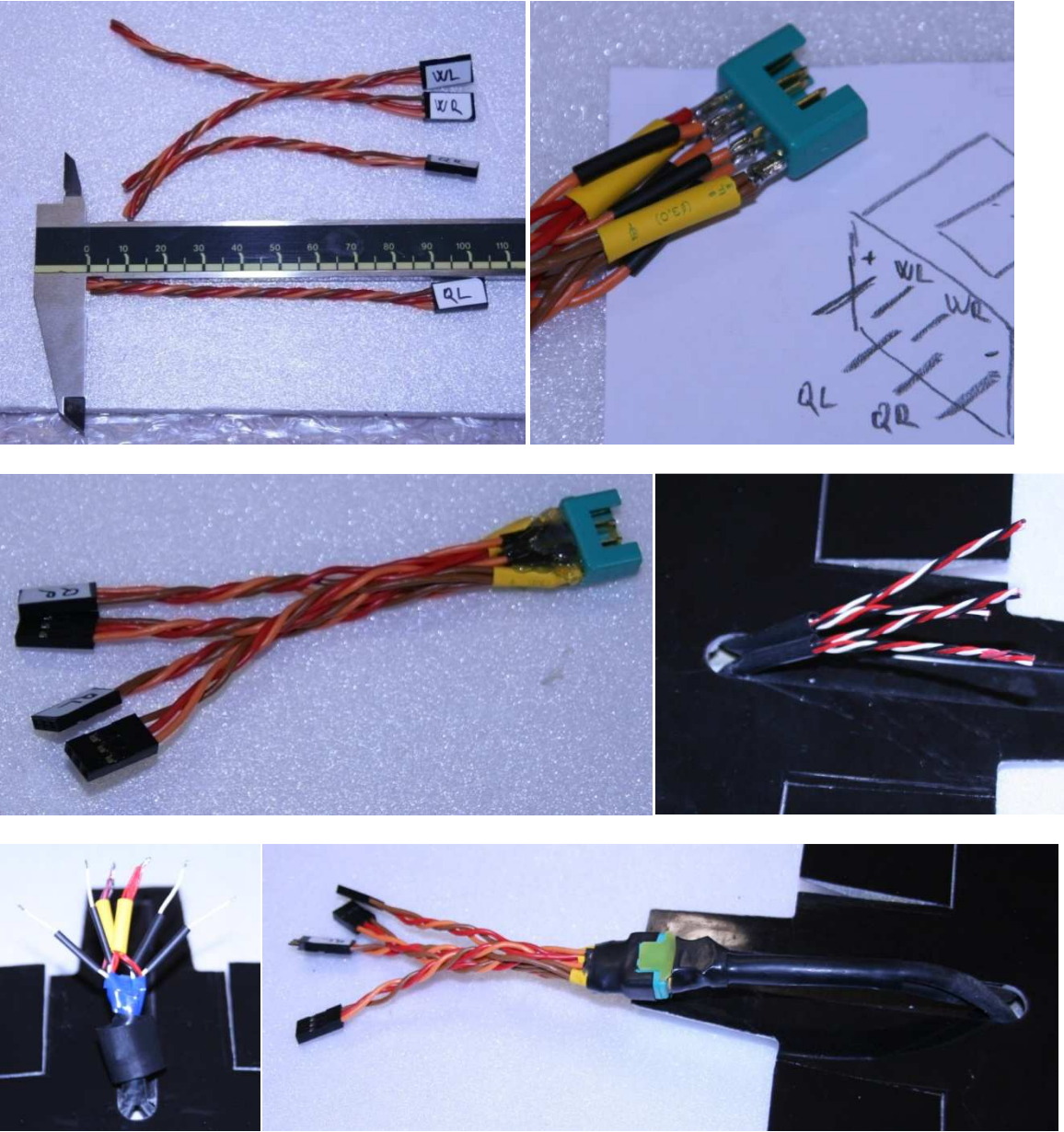

Picture 13: Connectors – wing/fuselage

3.4 Sticking up the servos into wing

First we set the neutrals¹¹ to all servos. We stick up the servos into wings with an epoxide. We ensure the ailerons and flaps to the wing in zero deflection by using a cellotape and we set the neutrals of all servos again.

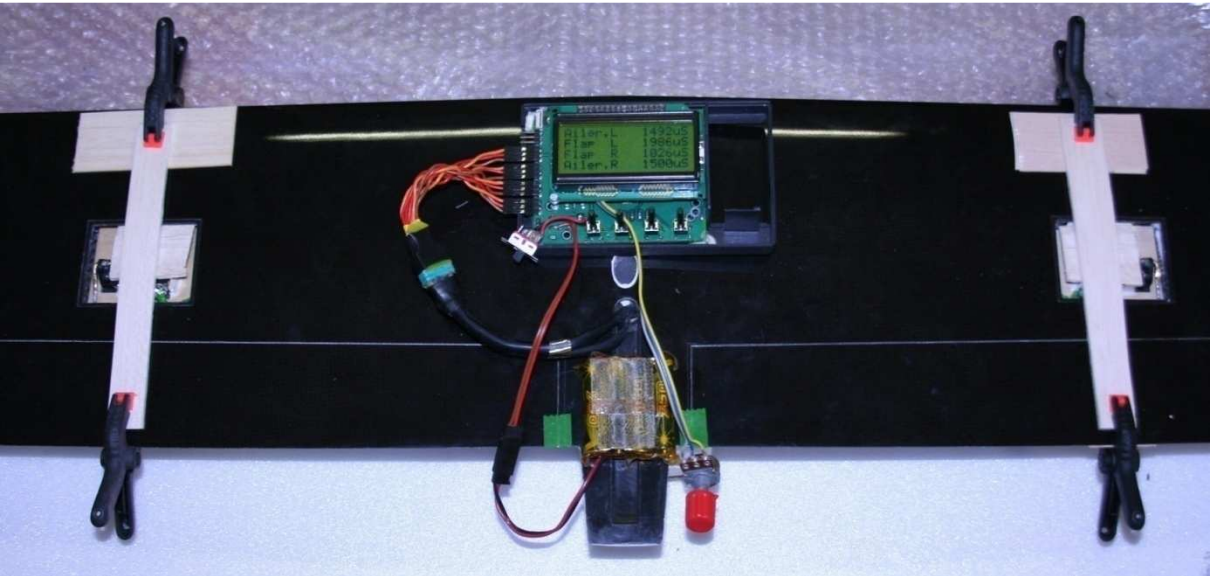
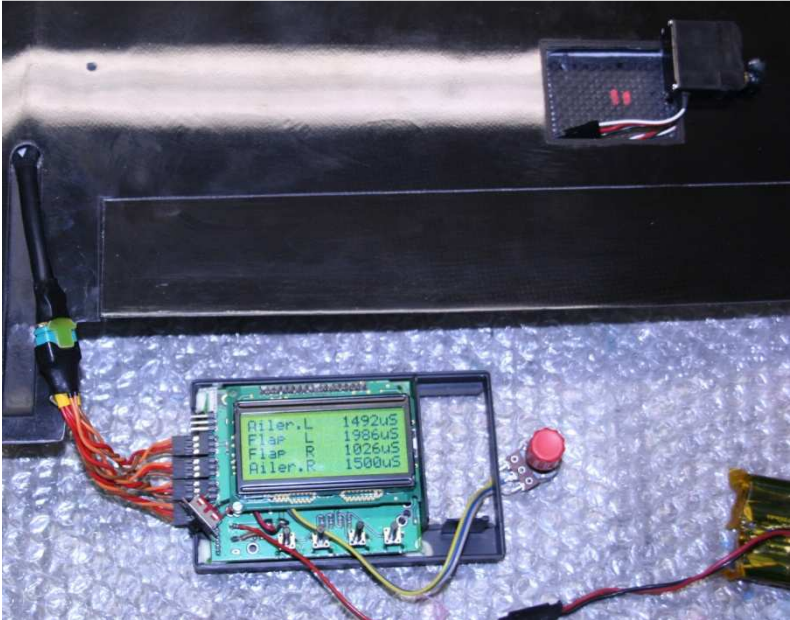

¹¹ The neutrals of the ailerons are c. 1500 µs and of the flapt c. 2000 µs and 1000 µs !!! Important!!!



Picture 14: Sticking the servos into wing

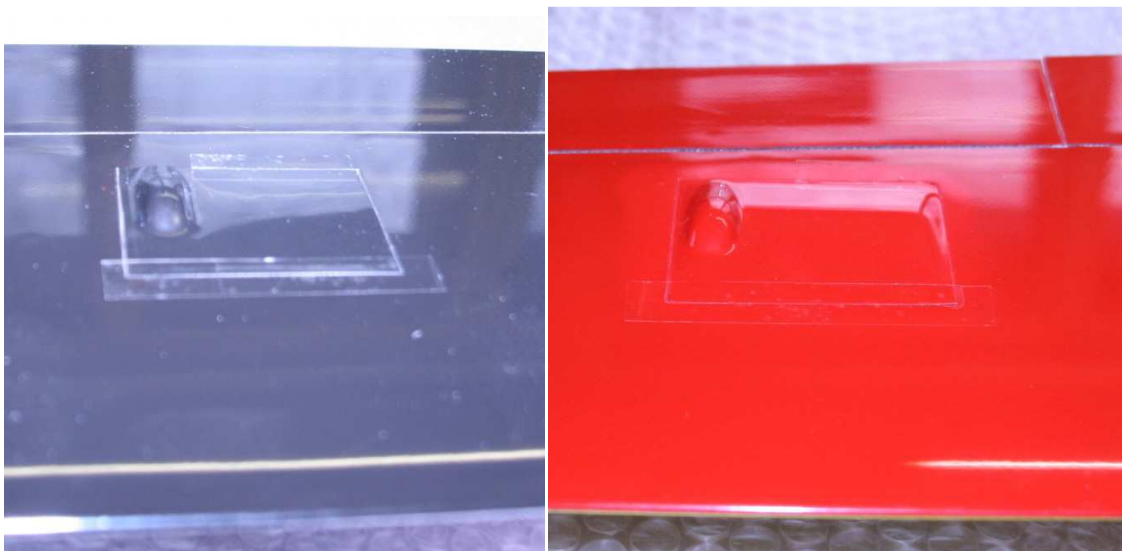

Picture 15: The servos' caps

It is necessary to use the external voltage supply for power supply. It is more reliable to use the connector 2mm instead of switch. The connector 2mm has a better contact. The conductors to the battery have the cross section 0,5mm².



Picture 16: Voltage supplies for the deck equipment

4 Others picture

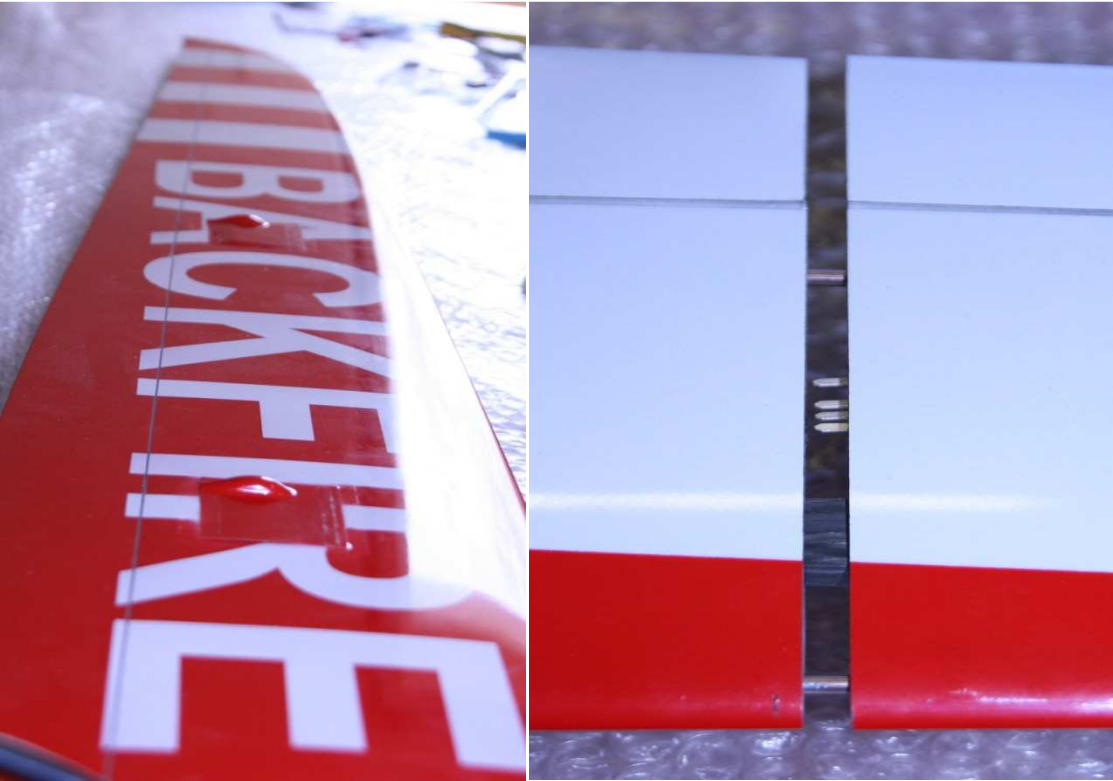

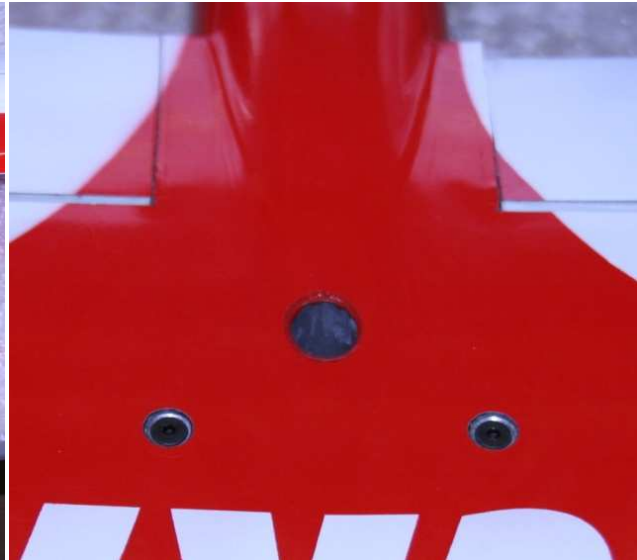

Picture 17: Input and output of the cooling air

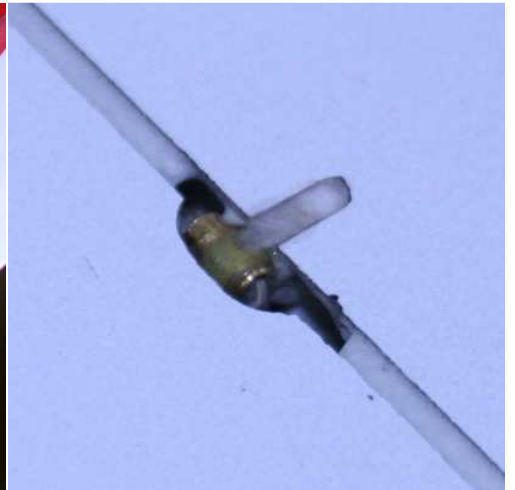



Picture 18: The tail piece of the fuselage, the divided wing

5 Deck Equipment

We place the receive batteries tight behind the engine with help of nails Dual-lock. We place the receiver in front of butterfly's servos. We hold the regulator also with nails Dual-lock on the top of the front part of fuselage. I recommend to use 2mm power connectors for the deck equipment instead of switch. It is possible to ensure the driving batteries against movement with help of nails Dual-lock as well. We choose the fixing of the battery to the bottom of fuselage according to the high of the driving battery, or we place the Dual-lock on the bottom of the wing and the top of the battery.

6 Setting of deflections, adjustment of phases and centre of gravity

6.1 Setting of servos' deflections

The advised setting as an informative one. Every pilot has different deflections habits and you can change this deflection after you get familiar with the model.

V-tail	-4mm ¹²	+4mm
Ailerons	-6mm	+4mm
Flaps	-1mm	+80°

Table 1: Setting of servos' deflections

6.2 Adjustment of flying phases

Function	Flaps	Ailerons	V-tail
Speed	-0,5mm	-0,5mm	-0,3mm
Thermik	+5mm	+3mm	-0,5mm
Landing	+80° ¹³	-3mm	+2mm

Table 2: Adjustmens of phases

6.3 Gravity center

The basic adjustment of gravity centre is **56mm** measured from entering edge. If you move the gravity centre forward the model will be more stable. If you move the gravity centre backward the model will better turn the basis turns.

7 The proofed gears

Model	Motor	Power batteries	Propeler	Regulator	Rising
Rekreation	SNeu 1509/1Y/6.7	4S 3700, 25C	16x16"	Castle Creations 125	40m/s
Competetion	SNeu 1509/1D/6.7	3S 4500, 33C	17x18"	Castle Creations 125	55m/s
Show	SNeu 1512/1D/6.7	4S 3700, 30C	17x18	Castle Creations 125	65m/s
Rekreation	Kira 500-44-6,7	4s 3200, 30C	15x16	Jive 100+LV	40m/s
Competetion	Kira 500-50-6,7	4S 3700, 30C	15x16	JazzFAI18/Jive 100+LV	55m/s
Show	Kira 600-38-6,7	4S 3700, 30C	16x17	JazzFAI18/Jive 100+LV	60m/s

¹² + deflection is ment as a positive one, so it is a down-deflection, and – deflection is ment as a negative one, so up-deflection

¹³ It is possible to heighten the flaps' deflection up to +90° when the undershooting is demand

Recreation	Hacker B50-9S+6,7	TopFuel 3800-3S	15x13	Master Basic 70-SB	
Competition	Hacker B50-5M+6,7-FAI	TopFuel 5000-3S	17x18	Master 195-O-F5B	55m/s
Show	Hacker B50-5L+6,7-FAI	4S 3700, 30C	17x18	Master 195-O-F5B	65m/s

8 Technical parameters

Wingspan	2440 mm
Length	1230 mm
Area	36,2 dm ²
Aspect ratio	18
Airfoil	DP 7,81
Empty weight	1,4-1,8 kg
Spinner	38 mm
Propeller	18"
CG	56 mm from LE

Backfire F5F

Aerodynamic

Dirk Pflug

Design + CAD/CAM

Ing. Petr Janku
Ing. Kamil Faja
Zbynek Kramek

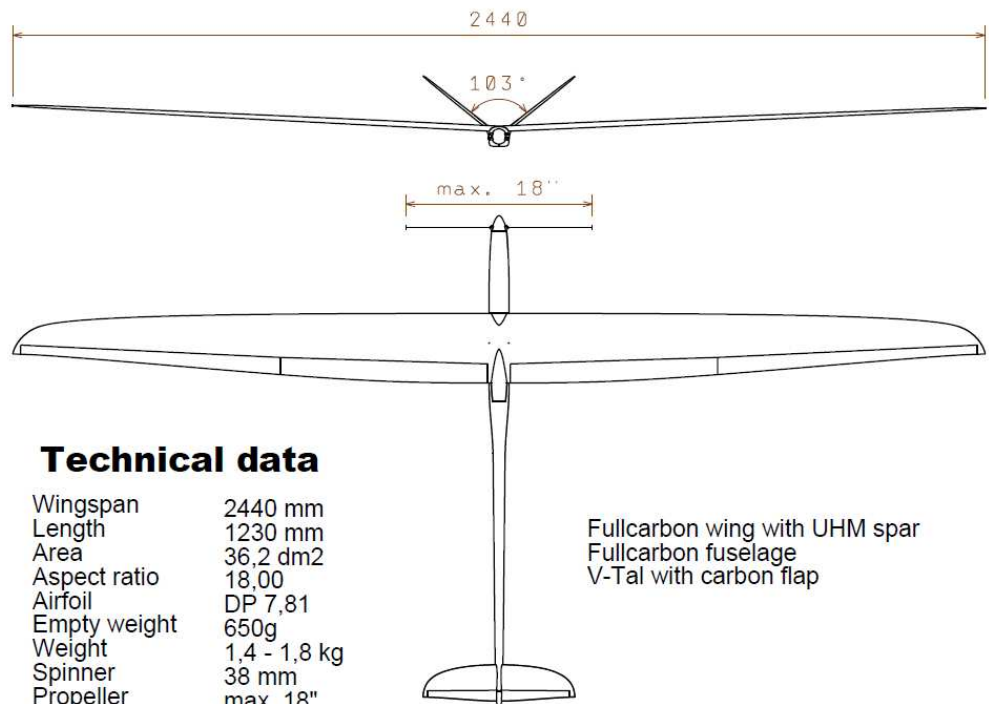
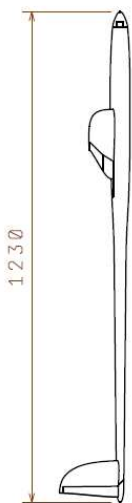

Technical data

Wingspan	2440 mm
Length	1230 mm
Area	36,2 dm ²
Aspect ratio	18,00
Airfoil	DP 7,81
Empty weight	650g
Weight	1,4 - 1,8 kg
Spinner	38 mm
Propeller	max. 18"
CG	58mm from LE

Fullcarbon wing with UHM spar
Fullcarbon fuselage
V-Tail with carbon flap